

The Glass Bottom Float Project – phase II

version 3, April 2009

Core project members:

Marc Böhlen, Dept. of Media Study, University at Buffalo

Joseph F. Atkinson, Dept. of Civil, Structural and Environmental Engineering, University at Buffalo

Project summary

The Glass Bottom Float (GBF) is an attempt to combine real time in situ water quality assessment strategies with experimental water quality measures to describe the possibility of a safe and pleasurable swimming experience.

The main components of the GBF are an instrumented platform located in the water near a swimming area and a data collection and dissemination system, so that data may be stored and documented for further use and also made available to potential swimmers.

GBF is a collaborative effort that combines not only proven scientific procedures with best practices of information design, but also established practices of local water quality observation professionals. GBF is both a new way to assess water quality as well as an additional instrument for researchers, beach operators and beach visitors who wish to observe and appreciate recreational waters.

Project objective

The objective of this study is to provide real-time information about water and swimming conditions to potential coastal recreation area visitors in New York. Our hypotheses are: (1) A water quality assessment measure that relates directly to an individual's recreational experience of that resource (such as swimming) has the potential to attract segments of the population previously unable to relate to abstract water quality assessment data; and (2) this measure can be more effective if it takes its target audience into consideration and is delivered with multimedia informed by best practices in information design.

Project history

We have established a community relationship with the beach operators and visitors at Woodlawn Beach where we tested, over the course of the summer of 2008, our main concepts, our sensor design and several aspects of our data dissemination strategy. Woodlawn Beach State Park, located on the eastern-most terminus of Lake Erie, three miles south of the city of Buffalo, offers a beautiful one mile long natural sand beach. Woodlawn is a reclaimed brownfield and the only urban beach operated by New York State Parks. Unfortunately, it is affected by sanitary sewer overflows as well as combined sewage overflows. Due to budgetary constraints of the State of New York, swimming will be restricted (if not prohibited) in 2009 at Woodlawn.

We have designed and constructed a robotic sensing platform with scientific quality data acquisition

devices. We use an art measurement sonde designed by YSI, the YSI6600V2-2 to measure turbidity, pH, water and air temperature, dissolved oxygen, chlorophyll (algae). The platform can robustly monitor these parameters according to best practices of beach side recreational water quality assessment. Our system also has a local weather station delivering real time data on air temperature, relative humidity, relative air pressure, wind speed . In addition to local weather, we query NOAA weather stations in our vicinity.

We have added intuitive, qualitative measures of water quality that are not included in the standard assessment of water quality. For example, we have a hydrophone based recording system with a linear frequency range of 1 to 50 kHz that captures underwater audio events. At present the event detection scheme uses zero-crossing frequency, signal power and frequency signature to discern events from non-events. Currently the events we can differentiate include speed boats passing by and people playing on the float and choppy waters. We also have included, but not yet full implemented, a commercial fish finder that delivers information on the presence of fish in a 60deg cone directly under the float, even in shallow waters. The device is capable of interpreting sonar signals to discern the presence of fish both large and small The sonar transducer is mounted on a passive pendulum system that maintains orthogonality to the seabed independent of wave motion. All these inputs are controlled by a single laptop computer with a solid-state hard drive in a water tight box. Two marine-grade, deep-cycle rechargeable batteries (12V, 55A/hr each) deliver the necessary power for the system to operate for 14 hours without recharging.

The current exploratory test bed is designed to accommodate the established beach monitoring procedures. The EPA stipulates that public swimming waters contain no more than 235 cfu of e-coli (coliform forming units). Since 2008, the e-coli concentration has been measured at Woodlawn Beach on a daily basis. Park employees send their water samples to an external laboratory for processing. The park manager enters the results into the park's log and into our system via a simple web-based interface, integrating the data from the external laboratory into our own system. Our sensor data, including recordings from the hydrophone are available on mobile phones with web connectivity.

GBF has received approval from the University at Buffalo's Social and Behavioral Sciences Review Board (IRB # IRB00003128) and can include human participants in the beach experiments.

Research agenda for 2009

We intend to continue the project and focus on the following key points for the summer of 2009.

- (1) Continue and expand data collection, including full day measurements.
- (2) System improvement: add wave height and presence of fish.
- (3) Definition a qualitative measure (SPM) of the potential for a pleasurable swimming experience that correlates the data collected by the sensors, beach operators and the public.
- (4) Compare the results from 2008 with those at a new site (as yet to be determined) in 2009.

Additional Information

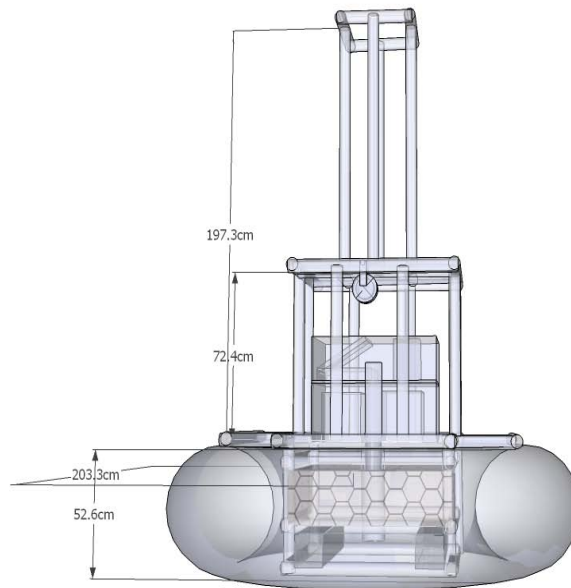

Schematic of the sensor core platform

The diagram does not include the anchor. We include a fortress marine anchor (FX11, aluminum) designed for use in boats up to 32feet in our setup. The weight of the system including equipment is about 70kg. 30Kg of dead weight will be added for stability. This weight is kept afloat by the inflated tube (approximately 1.2m³ air volume) and a polystyrene buoyancy billet capable of floating 100kg as a backup (honeycomb material in the schematic above).

Proposed test dates for phase II

July and August, exact days dependent on weather conditions.

Images from summer 2008 testing at Woodlawn Beach



Fig. 1
Transporting equipment to the beach,
July 2008.



Fig. 2
Equipment box, interior, July 2008



Fig. 3
Prototype buoy ready to be
deployed, July 2008.



Fig. 4
Sensor platform in quiet waters, July 2008

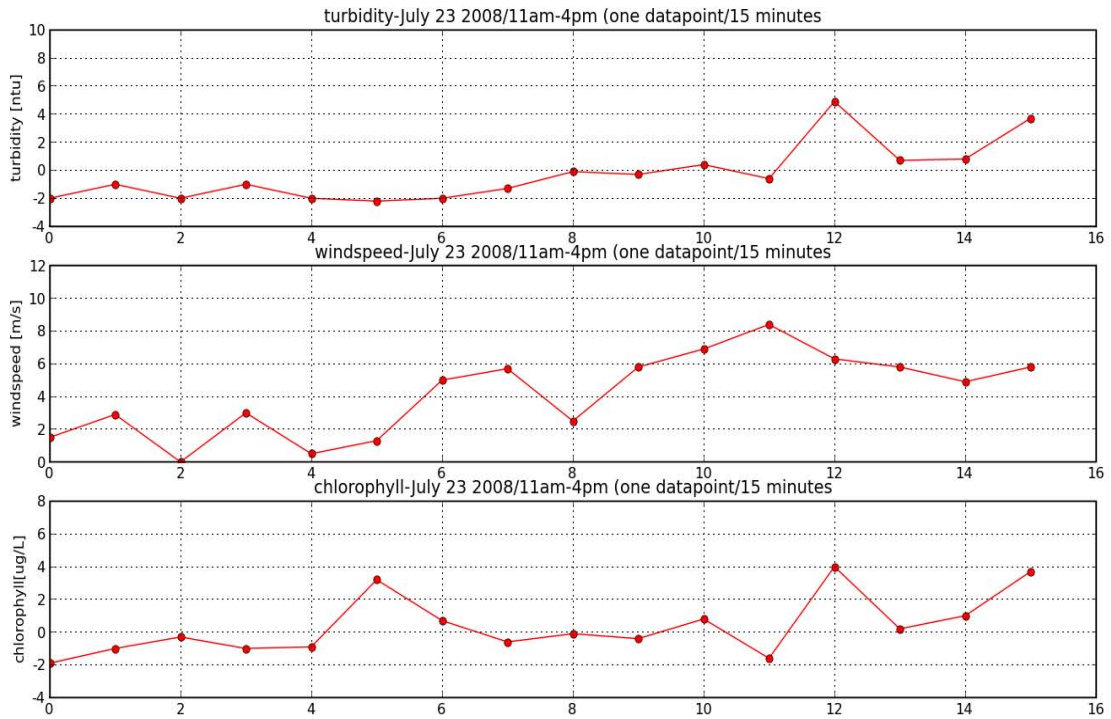

Fig. 5
Output of the local weather system
on a mobile phone, July 2008



Fig. 6
Platform during a thunder storm,
July 2008

Fig. 7
 Plotting the data collected during
 the storm, July 2008
 (units of measurement are relative; no
 negative turbidity or chlorophyll)



Document history

- Document (version 3) sent to David Clark (Beaver Island State Park) on April 16th 2009.
- revised April 29, 2009: IRB approval added.